



Designation: D3838 – 05 (Reapproved 2011)

## Standard Test Method for pH of Activated Carbon<sup>1</sup>

This standard is issued under the fixed designation D3838; the number immediately following the designation indicates the year of original adoption or, in the case of revision, the year of last revision. A number in parentheses indicates the year of last reapproval. A superscript epsilon ( $\epsilon$ ) indicates an editorial change since the last revision or reapproval.

### 1. Scope

1.1 This test method covers determination of the pH of a water extract of activated carbon.

1.2 The values stated in SI units are to be regarded as standard. No other units of measurement are included in this standard.

1.3 *This standard does not purport to address all of the safety concerns, if any, associated with its use. It is the responsibility of the user of this standard to establish appropriate safety and health practices and determine the applicability of regulatory limitations prior to use.* For specific hazard statements, see Section 6.

### 2. Referenced Documents

#### 2.1 ASTM Standards:<sup>2</sup>

- D1193 Specification for Reagent Water
- D1293 Test Methods for pH of Water
- D2867 Test Methods for Moisture in Activated Carbon
- D6851 Test Method for Determination of Contact pH with Activated Carbon
- E300 Practice for Sampling Industrial Chemicals

### 3. Summary of Test Method

3.1 An activated carbon sample is boiled in reagent water using a reflux condenser to recycle water vapor. The particles of carbon are filtered out, the filtrate cooled to 50°C and the pH of the filtrate determined by electrometric measurement.

### 4. Significance and Use

4.1 When a fluid containing an adsorbate is passed through a bed of activated carbon, chemical reactions may take place between the activated carbon, its other noncarbonaceous con-

stituents, and the adsorbate containing fluid. The pH of the carbon may be a significant parameter of such a reaction and therefore may be an important characteristic of the carbon.

### 5. Apparatus and Materials

- 5.1 *Analytical Balance*, capacity 100 g, precision  $\pm 0.01$  g.
- 5.2 *Hot Plate*.

5.3 *Glassware for Boiler-Reflux Condenser Apparatus* (Fig. 1)—Items shown are for guidance only, providing a convenient set of equipment available off-the-shelf from many laboratory supply houses. The “all-glass” elements, with standard-taper and ball joints, provide freedom from contamination and maintenance. A check valve in the position shown is essential to relieve pressure buildup while minimizing loss of vapor.

5.4 *Thermometer*, glass, approximately 0 to 120°C, long enough to be read at 100°C when inserted to bottom of Erlenmeyer flask in Fig. 1.

5.5 *Thermometer*, glass, approximately 20 to 55°C.

5.6 *Graduated Cylinder*, 100-mL.

5.7 *Beaker*, 200-mL.

5.8 *Filter Funnel*.

5.9 *Filter Paper*, qualitative, medium flow rate, 12.5 cm or larger in diameter.

5.10 *Timer*.

5.11 *pH Meter*, in accordance with Test Methods D1293, Type II (automatic thermal compensation preferred).

5.12 *Reagent Water*, in accordance with Specification D1193, Type II.

### 6. Hazards

6.1 The test method involves transfer of boiling water between containers; appropriate tongs or gloves should be used. In addition, the use of an electric hot plate and pH meter (if line-powered) poses a shock hazard. This equipment must be grounded and insulated in accordance with UL standards and electrical codes.

### 7. Sampling

7.1 Guidance in sampling activated carbon is given in Practice E300.

<sup>1</sup> This test method is under the jurisdiction of ASTM Committee D28 on Activated Carbon and is the direct responsibility of Subcommittee D28.02 on Liquid Phase Evaluation.

Current edition approved March 1, 2011. Published May 2011. Originally approved in 1980. Last previous edition approved in 2005 as D3838 – 05. DOI: 10.1520/D3838-05R11.

<sup>2</sup> For referenced ASTM standards, visit the ASTM website, [www.astm.org](http://www.astm.org), or contact ASTM Customer Service at [service@astm.org](mailto:service@astm.org). For *Annual Book of ASTM Standards* volume information, refer to the standard's Document Summary page on the ASTM website.

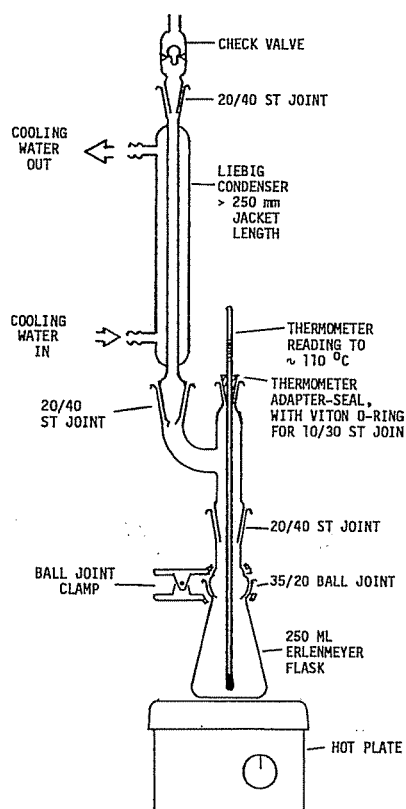

FIG. 1 Boiler-Reflux Condenser Apparatus

### 8. Calibration and Standardization

8.1 Use the procedure of Test Methods D1293 to standardize the pH meter.

### 9. Procedure

9.1 Determine the moisture content of the carbon in accordance with Test Method D2867. Calculate the weight of moist carbon equivalent to 10 g on a dry basis.

9.2 Weigh out a sample of carbon equivalent to  $10.00 \pm 0.01$  g on a dry basis. Remove boiler flask from apparatus and add carbon sample.

9.3 Bring approximately 110 mL of reagent water to a gentle boil. Measure  $100.0 \pm 0.1$  mL in graduated cylinder while water is hot. Immediately add this water to the carbon in the flask. Reconnect joints to flask seated on hot plate.

9.4 Bring water in flask to a boil, using thermometer reading to assure that no false boiling, due to gases trapped in carbon, occurs.

9.5 Boil gently for  $900 \pm 10$  s.

9.6 Remove the flask from the hot plate and filter its contents immediately through the filter paper premoistened with the distilled water used for the test. Catch the filtrate in a

500-mL vacuum filter flask, being careful to prevent carbon-fines from overrunning into the flask.

9.7 Cool the filtrate to  $50 \pm 5^\circ\text{C}$ .

9.8 Measure pH as described in Test Methods D1293.

### 10. Calculation

10.1 If the pH meter is calibrated in pH units, read value from pH meter. If the meter reading is in voltage units, use the equation from the Terminology section of Test Methods D1293.

### 11. Report

11.1 Report the following information:

- 11.1.1 Source of sample,
- 11.1.2 Type or designation of activated carbon,
- 11.1.3 Supplier name,
- 11.1.4 Supplier grade designation,
- 11.1.5 Supplier lot and batch number,
- 11.1.6 Moisture content in accordance with Test Method D2867,
- 11.1.7 pH to the nearest 0.1 unit,
- 11.1.8 Temperature of measurement to the nearest  $1^\circ\text{C}$ ,
- 11.1.9 Date of test,
- 11.1.10 Name and signature of technician performing test, and
- 11.1.11 Name and signature of supervisor approving test.

### 12. Precision and Bias

12.1 An interlaboratory comparison of the pH of four types of activated carbons using essentially the above procedure was carried out by four laboratories (see Test Method D6851). The results were as follows:

Sample	Number of Tests	Average pH	Standard Deviation
2N	11	3.65	0.18
11N	12	3.64	0.19
12N	11	3.56	0.14
1D	11	5.57	0.67
4D	12	5.62	0.60
9D	12	5.65	0.60
3B	11	8.82	0.38
5B	12	8.93	0.30
10B	12	8.90	0.29
6P	11	7.91	0.17
7P	12	8.07	0.41
8P	12	7.85	0.23

12.2 The measured pH values are in agreement with the activated carbon types (N, wood-base; D, lignite; B and P, bone-char). The standard deviations also appear in agreement with other work, in that they are higher for neutral conditions (near pH 7) than for strongly acidic or basic conditions. Some of the observed variation is in the samples themselves. A standard deviation of 0.6 for pH values near 7 and 0.3 for values at the ends of the pH scale appears readily achievable by this test method.



## D3838 – 05 (2011)

ASTM International takes no position respecting the validity of any patent rights asserted in connection with any item mentioned in this standard. Users of this standard are expressly advised that determination of the validity of any such patent rights, and the risk of infringement of such rights, are entirely their own responsibility.

This standard is subject to revision at any time by the responsible technical committee and must be reviewed every five years and if not revised, either reapproved or withdrawn. Your comments are invited either for revision of this standard or for additional standards and should be addressed to ASTM International Headquarters. Your comments will receive careful consideration at a meeting of the responsible technical committee, which you may attend. If you feel that your comments have not received a fair hearing you should make your views known to the ASTM Committee on Standards, at the address shown below.

This standard is copyrighted by ASTM International, 100 Barr Harbor Drive, PO Box C700, West Conshohocken, PA 19428-2959, United States. Individual reprints (single or multiple copies) of this standard may be obtained by contacting ASTM at the above address or at 610-832-9585 (phone), 610-832-9555 (fax), or [service@astm.org](mailto:service@astm.org) (e-mail); or through the ASTM website ([www.astm.org](http://www.astm.org)). Permission rights to photocopy the standard may also be secured from the ASTM website ([www.astm.org/COPYRIGHT](http://www.astm.org/COPYRIGHT)).

订单号:201107071510184245 购买日期:2011-07-07 授权用户:煤炭科学研究总院

由中国标准化研究院标准馆<sup>3</sup>根据ASTM授权协议进行销售  
地址:北京市海淀区知春路4号 邮编:100088 电子邮件:[guodh@cnis.gov.cn](mailto:guodh@cnis.gov.cn)